

INSTALLATION, OPERATION AND MAINTENANCE MANUAL FOR AIL SINGLE PIECE & TWO PIECE FULL BORE BALL VALVES

1.0 STORAGE OF VALVES

On receipt, check the valve to ensure that it is in fully assembled condition and in the open position.

End protectors on the valve should be kept intact and removed only at the time of installation. Valve performance depends on prevention of damage to the ball/seat surfaces.

Valves should be stored in a covered area. If covered area is not available any water proof covering material should be spread over the valves and they should be kept on a wooden pallet at least 150mm above the ground level.

Do not apply tar, paint, grease or any other material inside the valve or on the stem, as this could impair the performance of valve.

2.0 INSTALLATION

2.1 GENERAL

When despatched, valves contain a rust preventor and if necessary may be removed with a solvent.

Before installation ensure that the pipeline has been flushed on line scale, weld spatter, rust and other foreign matter.

Ensure that the end protectors are removed at the time of installation.

3.0 OPERATION

3.1 GENERAL

AIL Ball valves provide bubble tight shut off when used in accordance with our published pressure/temperature chart.

It is not the right practice to leave the valves in a partially open (throttled) position as this can damage the seats and adversely affect its performance.

Any media that may solidify, crystallise or polymerise should not be allowed to remain in the valve cavity as it can affect the operation of the valve.

3.2 MANUAL OPERATION

AIL Ball valves have a quarter turn operation, closing in a clockwise direction. It is possible to determine when the valve is open or closed by the position of the lever. When the lever is in line with the pipeline, the valve is open, and when at 90° to the pipeline it is closed.

3.3 REMOTE OPERATION

When manual operation is not desired, valves may be automated for remote operation. A range of pneumatic/ electric actuators and gear units are available for mounting on AIL Ball valves.

No stopper plate is fitted on actuated valves/gear unit valves, as the stop is normally a part of the actuator/gear unit.

For operational details of the actuators, refer to installation manual of the actuator.

4.0 MAINTENANCE

4.1 GENERAL

AIL Ball Valves have a long trouble free life, and maintenance is seldom required. But when necessary, valves may be refurbished very easily by using few components, which do not require machining at site. AIL Ball Valves are designed for easy service and assembly in field. The following points would, however, help to extend valve life further, or reduce operational problems.

4.2 STEM LEAKAGE

Remove the wrench assembly. Examine the disc springs (Belle Ville Washer - applicable upto 40mm) for damage. If in exact condition, tighten the gland nut until the disc springs are fully compressed. If damaged, dismantle the stem down to the gland, fit new disc springs with their outer edges touching and tighten using a new gland nut. Further maintenance requires dismantling of the valve.

If the stem leakage is not arrested by the above procedure, dismantle the valve. However do not disturb the stem assembly if no stem leakage is noticed.

4.3 IN-LINE THROUGH LEAKAGE

Check that the valve is fully closed condition. If it is, then the leakage is possibly due to a damaged seat/ ball or sealing surfaces and it will be necessary to dismantle the valve to rectify it.

4.4 REFURBISHING

Use only genuine AIL Ball Valve spares. These can be ordered on our distributors and authorised stockists.

Parts of valves from different sizes of series must not be interchanged.

This is important as it ensures that the valve is capable of being used for the purpose it was designed and constructed and operated without risk to health and safety.

4.5 SAFETY PRECAUTIONS

Before removing the valve from the pipeline, ensure that adequate safety precautions are taken, as the media flowing through the valve may be corrosive, toxic, inflammable or contaminated. It is advisable to use safety gear like eye shields, gloves and safety shoes.

Ensure that before removing the valve from the line no pressure exists on the upstream or downstream sides of the valve.

Before removing the valve ensure that any trapped media is released by opening the valve slowly to half open position.

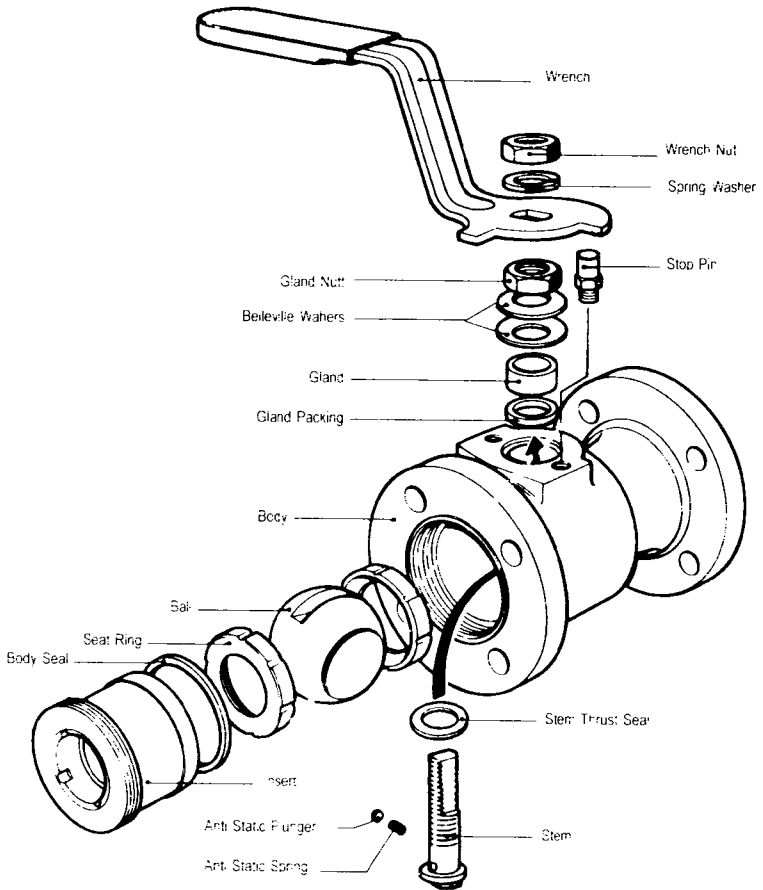

Exploded view of Ball valve 15mm to 40mm

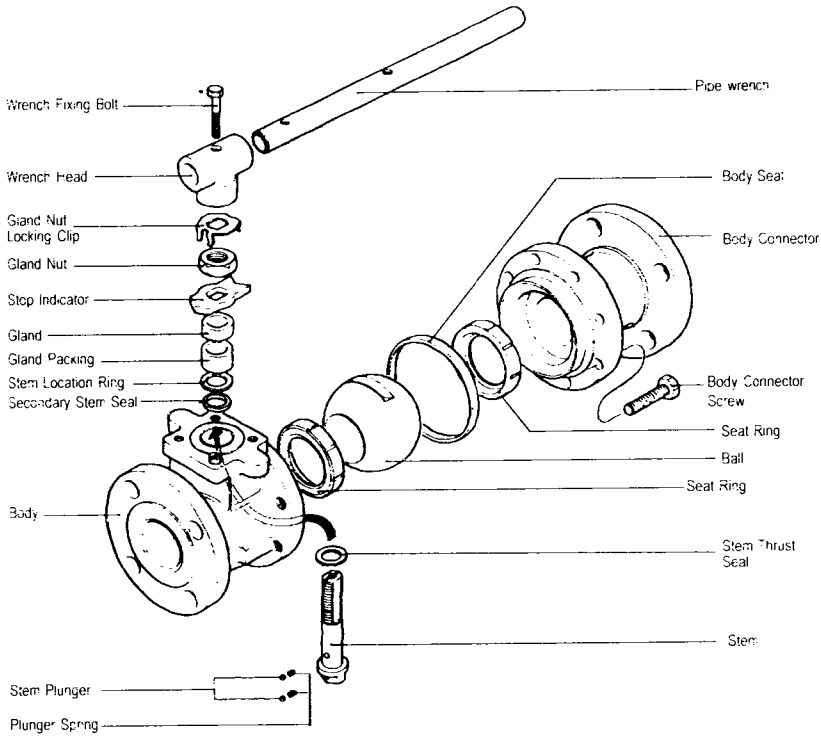

Exploded view of Ball valve 50mm and above

4.6 DISMANTLING

Remove the valve from the pipeline by extracting the flange bolting from each end. Large pipelines (sizes 80mm and above) have a tendency to spring the flanges and removal can be difficult. If necessary remove elbows, couplings or pipe supports to get extra maneuverability.

The valve can be removed in either the open or closed position.

However, if it is open, it ensures that no line media lies pressurised within the valve cavity.

With the valve securely clamped (vertically, insert side facing the top) and in the open position, undo the insert using the appropriate drive adaptor. It may be necessary to use a heavy mallet on the tommy bar of the insert tool to break the metal to metal seal and move the insert initially.

Remove the insert to allow access to the cavity. The insert should be removed out of the body completely as otherwise its seal face may be damaged (not applicable for 2 piece design).

In case of 2 piece design, remove the interconnecting bolts between body and body connector.

Remove the body seal and discard. If the seal is difficult to remove than use a scriber or sharp bladed screwdriver and dig into the body seal at an angle far enough to provide positive location. Lever out one section of the seal from its recess and pull it out using a long nose pliers.

Close the ball and using a soft drift through the body port, tap out the ball and insert seat.

Turn the stem back to the open position and using a suitable hook pull out the body seat being careful not to damage the seat sealing face and the fire safe lip on the valve body.

To dismantle the stem assembly remove the wrench nut, washer and wrench from the stem. Using the wrench to prevent the stem from turning, remove the gland nut and the gland. Tap the stem down and withdraw it from inside the body. The gland packing, o' ring and the stem seal can now be removed from their recesses (from 50mm onwards), being careful not to damage the seal faces.

All components must be inspected for wear and damage. Parts that are not to be replaced should be thoroughly cleaned and stored in a clean area. All sealing faces on the body, insert and ball must be checked for corrosion, erosion and scratches. If damage is found or there is any doubt, replace the component.

Cleaning of valve parts should be carried out using a suitable degreasing agent. Hard deposits can be removed using wire wool or by using a hard blunt tool. Care should be taken not to damage or scratch any of the seal faces and machined faces.

4.7 REBUILDING

Before rebuilding, check that all the correct components are available and they are fit for the purpose. When rebuilding cleanliness is essential to

allow long valve life and provide cost effective maintenance

Fit the new gland packing into the body recess, the gland and new disc springs (with their outer edges touching) onto the stem. This is applicable only upto 40mm size.

Fit the gland nut, prevent the stem from turning and tighten down to fully compress the disc springs (only upto 40mm size).

Fit the wrench, washer and wrench nut to the stem and operate the stem to the valve open position.

Secure the valve in a vertical position, with insert side facing upwards (upto 40 mm) or body connector facing upwards (from 50mm & above). With the body seat end on, enter it into the valve cavity past the stem drive tang, then position it into the seat housing. A silicon based grease may be applied to the seat face to aid bedding in of the valve.

Turn the stem to valve closed and slide the ball into the body locating the stem drive tang.

Having applied silicon grease for sizes upto 40mm locate the insert end seat into the cavity and the body seal into the housing. For sizes 50mm and above, locate the body connector end seat into the cavity and body seal in to the housing.

Open the valve and screw the insert for sizes upto 40mm into the valve body using a suitable drive adaptor for sizes 50 mm & above body connector should be put into the body and tighten the fasteners. It is important that on stainless steel valves an anti scuffing

compound is used on the insert thread. It is advisable, though not mandatory to use it on carbon steel valves.

The valve is now ready to be put in line. If possible, leak tightness and ease of operation should be checked.

Installation, Operation & Maintenance Manual for AIL Ball Valves (3-PIECE DESIGN)

1. STORAGE OF VALVES

On receipt, check the valve is in fully assembled condition and in open position.

End protectors on the valve should be kept intact and removed only at the time of installation. Valve performance depends on prevention of damage to the ball surface.

Valves should be stored in a covered area. If covered area is not available any water proof covering material should be spread over the valves and the valves should be kept on a wooden pallet atleast 6" above the ground level.

Do not apply tar, paint, grease or any other material inside the valve or on the stem, as this could impair the performance of the valve.

2. INSTALLATION

General

When despatched, valves contain a rust preventive and this may be removed with a solvent if necessary.

Before installation remove all foreign matter in the pipeline by flushing the line with the water or compressed air, keeping the valve fully open.

SCREWED END VALVE

Do not dismantle the valve for installation. Screwed ends should not be fitted independently, treat the valve as a single unit. taper threaded fittings should not be over tightened.

WELD END VALVE

The instruction sent along with each valve must be followed.

3. OPERATION

AIL Ball Valves have a quarter turn operation-closing in a clockwise direction. It is possible to determine when the valve is open or closed by the position of the lever. When the lever is in the line with the pipeline, the valve is open: when the lever is across the pipeline, the valve is closed.

Where manual operation is not desired, valves may be automated for remote operation. A range of pneumatic actuators is available for mounting on AIL Ball Valves.

No stopper plate is fitted to the remote operated valve, as the stop is normally a part of the actuators.

For operational details of the actuators, refer installation manual of the actuator.

4. MAINTENANCE

General

ALL Ball Valves have a long, trouble-free life, and maintenance is seldom required . But, when necessary, valves may be refurbished very easily by using few components, which do not require machining at site. ALL Ball Valves are designed for easy service and assembly in the field. The following checks would however, help to extend valve life further, or reduce operational problems.

Stem Leakage

Examine the disc springs (Belle Ville washer) for damage. If in exact condition, tighten the gland until disc springs are fully compressed. If damaged, dismantle the stem down to the gland, fit new disc springs with their outer edges touching and replace using a new gland nut. Further maintenance necessitates dismantling of the valve.

Leakage at body joint

Check for tightness of the body connector bolts. If slack, tighten the bolt using standard wrenches only. Avoid excessive force as this will be due to the damaged body connector seal and oil will be necessary to dismantle the valve.

In line leakage

Ensure that the valve is fully closed. Leakage if noticed will be due to a damaged seat or ball seating surfaces and it will be necessary to dismantle the valve.

If the stem or body leakage is not arrested by the above simple procedure, dismantle the valve. However, do not disturb the stem assembly if no stem leakage is noticed.

Leakage at pipeline joint

Screwed Valves

Test for tightness of screwed ends. If slack, tighten with standard wrench - excessive force will only split the connector. normal jointing material should be used in the correct quantity.

Weld end valves

After welding the valves as per procedure detailed in para 8, pressure test the welded joints for leakage. If necessary re-weld again as per the procedure.

5. REFURBISHING

Spare parts can be ordered on our Distributors and Stockists.

Where a valve needs repairing, rather than maintaining, it must be noted that only genuine spare parts should be used.

Parts of valves from different series, should not be interchanged.

This is to ensure that the valve remains capable of being used for the purpose for which it was designed and constructed and operated without risk to health and safety.

Tools

No special tools are required for maintenance of AIL Ball Valves of 3 piece design.

6. SAFETY PRECAUTIONS

Before removing the valve from pipeline, ensure that adequate safety precautions are taken, as media flowing through the valve may be corrosive, toxic, inflammable or contaminated. It is advisable to use safety gear like eye-shields, gloves, & footwear.

Ensure that before dismantling the valve no pressure exists either on upstream or downstream sides of the valve.

Ensure that any trapped media is released by operating the valve slowly to half open position (decontamination).

Body connectors form an integral part of the pipeline and the valve cannot be removed from the pipeline without being dismantled(see DISMANTLING Procedure detailed in Para 7).

7. DISMANTLING

If the valve is closed and not in fully open position, refer to the safety precautions before proceeding further.

Also, during dismantling, do not assume that the valve is totally decontaminated as harmful fluid, may still be trapped in crevices.

To remove valve from pipeline, extract body connector bolts and slide the body out from between the body connectors. It is often not necessary to remove the body completely away from the pipeline, in such cases, remove three of the body connector bolts,

and with the fourth bolt slackened, the body may be rotated out from the line using the fourth bolt as hinge. (Refer fig.1)

The **ball must be in the open position** since a closed ball protrudes beyond the body cavity and ball will be damaged against body connectors when body is removed or rotated.

If the body connector seals come away easily during removal of body, they may be removed at that time. If not, leave them until later .

When the body is free of the body connectors, turn valve to half closed position and hook out seats with finger. Complete the closing turn and - the ball may be pushed out to fall on to- hand- this must be done carefully, otherwise the ball will mark against the body.

The body connector seals should now be removed. Care must be taken to avoid scratching the machined faces on which they make contact with the valve body.

To dismantle stem assembly, first remove the lever nut, identification plate and lever from stem. Using lever to prevent the stem from turning the gland nut, disc springs and gland. It is not normally possible to remove gland packing at this stage. Withdraw stem through body cavity and remove stem thrust seal from stern or body recess. Gland packing may now be removed.

In the 15mm size, the wrench flats on the stern must be aligned perpendicular to the line to allow withdrawal of the stem.

Clean all components thoroughly and examine all seatings/sealing surfaces.

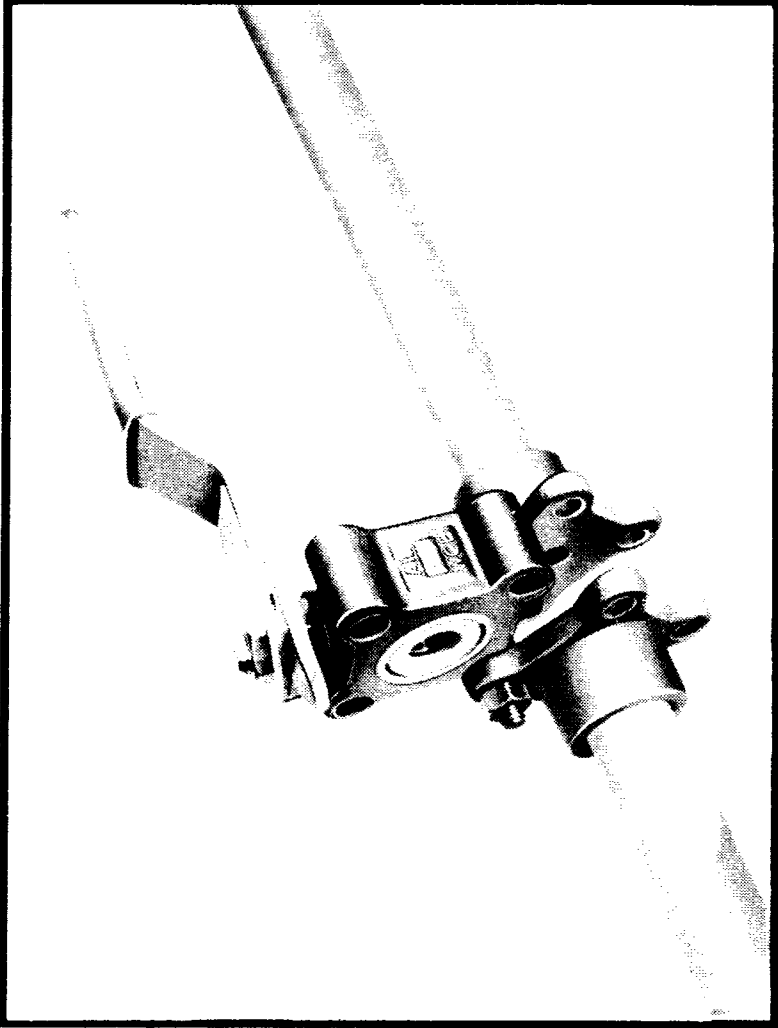

FIG. 1

If there is a build - up of solids which cleaning fluids will not dislodge-do not scratch the machined surfaces- use a broad, flat, blunt tool.

No eroded or corroded leak parts are permissible. If any are found, the part must be replaced. The ball should not have scratches across its seating surfaces as any damage to the port lip as this will destroy the seats. A damaged ball must not be re-used, fit a new one .

8. REBUILDING (Refer Fig. 2)

Before rebuilding, check that all the correct components are available and that they are fit for the purpose. When rebuilding, cleanliness is essential to allow long valve life and provide cost effective maintenance.

Fit stem thrust seal to stem and insert stem through body cavity into stem hole and fully up into body recess. Fit gland packing, gland and disc springs with their outer edges touching Using lever to prevent stem from turning, fit gland nut and screw down until disc springs are firmly compressed. Operate stem several times and re-adjust. Overtightening will only reduce the life of the assembly. Now fit stop plate, lever, identification plate and lever nut to stem assembly and move lever to the closed position (lever across the pipeline). In sizes 1/2" & 3/4" lever has integral stopper and there is no separate stop plate.

With the lever still in the closed position, the ball may be inserted into the body cavity by sliding the ball slot over the stem tang. Open the valve.

The **ball must be in the open position** since a closed ball protrudes beyond the body cavity and ball will be damaged against

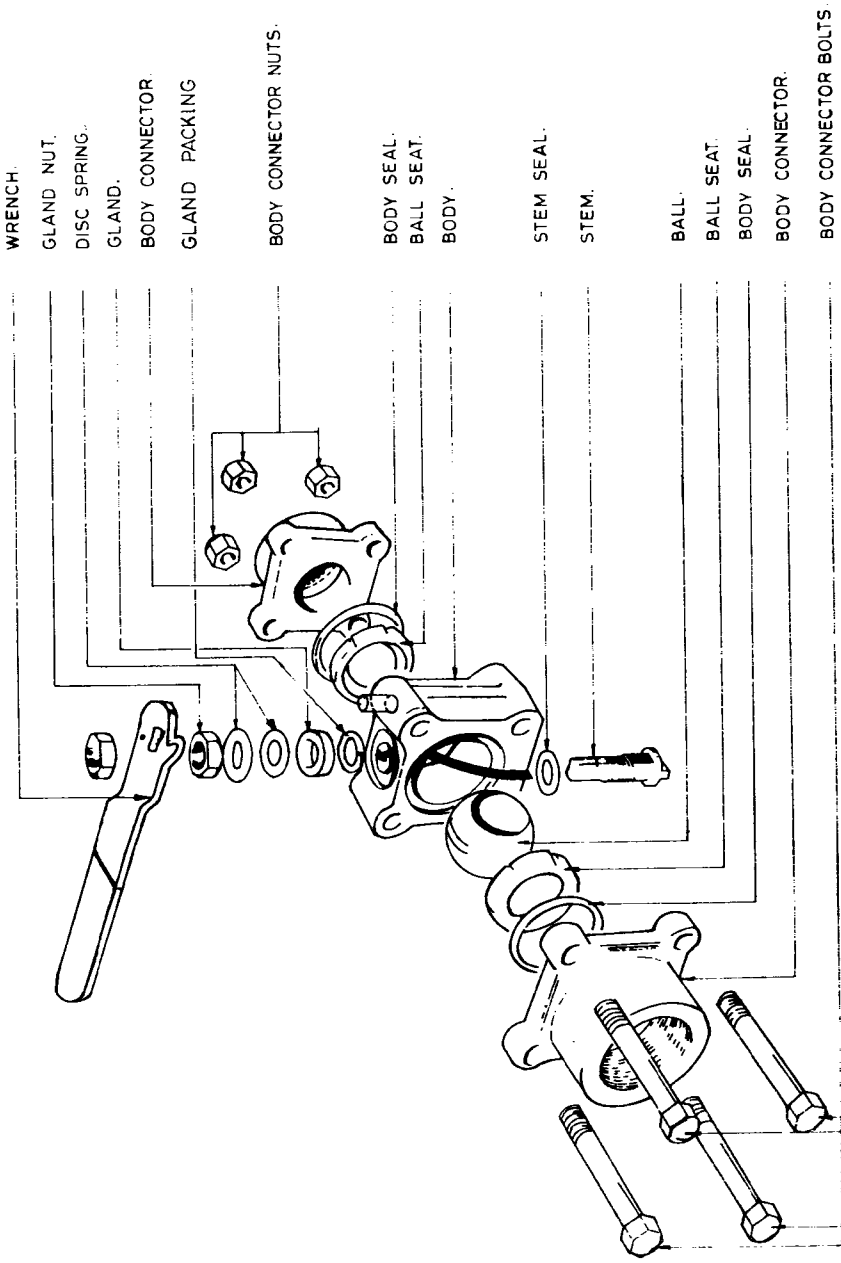

Fig 2

body connectors when the body is removed or rotated . Also, with the valve in the open position, the ball is retained by the stem tang and cannot fall out of the body cavity.

The seat rings and body connector seats may now be fitted.

A trace of lubricating oil or petroleum jelly, if compatible with the future pipeline media , will ease the rebuilding by holding the seat rings and body connector seals in place. Do not use greases with abrasive additives.

The valve may be installed back in to the pipeline by sliding the body in between the body connectors. The pipeline should, however, be sprung apart sufficiently to clear valve body and avoid damage to seat rings, body connectors seals and body connectors sealing face.

Locate body on center line of pipework, fit body connector bolts and nuts and by tightening, pull together body connectors. Use only standard wrenches for tightening, as excessive force will only stretch or strip the studs.

Welding instructions for socket weld ends - AIL Ball Valves (Size 1/2" to 2")

1. Prepare clean working area.
2. Smoothen pipe ends to remove any burrs.
3. With valve in OPEN position, remove the body connector bolts. Remove the body connectors from body and turn the ball to part closed position.
4. Carefully remove the ball seats and body seals. Supporting the ball so as to prevent it from falling out of the body, turn to closed position and remove the ball.

5. Place all removed parts in clean and secured position.
6. Reassemble the body alone with body connectors and tack weld only the valve to the pipeline. Remove the body to prevent damage to stem seals from welding heat.
7. Then complete the welding, ensuring that body connector faces are protected from weld splatters.
8. When cool clean body connector faces carefully.
9. Fit the ball, ball seats and body seals into the body.
10. In the case of ball valves with graphite body seals (eg.AW44) care should be taken that the body seals are not damaged during disassembly. For this the valve is tack welded into pipeline without applying excessive heat. Then the body assembly is removed intact. Do not remove body seals as they are very brittle and likely to break, if not handled properly. Then weld the end connections as explained in steps 8 & 9 .
11. Ease body assembly between body connectors carefully, keeping the ball in open position, without damaging faces or seals.
12. Replace body connector bolts and working in a diagonal order tighten the nuts firmly.

Test

A test for leak tightness is recommended.